

Specifications for 2C Panel IT: 2C861

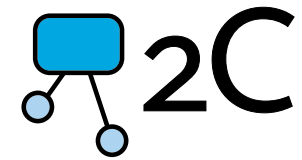

Features:

- Fits most 40" - 72" flat panel displays
- VESA Compliance (All in mm):
 - 200 x 400
 - 400 x 400
 - 400 x 600
 - 400 x 800
 - 600 x 800
 - 700 x 800 (max)
- Can add on 2C860T (Glass tray) and 2C860C (Camera mount)
- Can easily swivel to landscape or potrait position
- With incorporated security slot
- Integrated cable management
- Mounting and installation hardware supplied
- Locking Castor type rear wheels
- Mobile - Easy 360° Flexible wheel movement
- Material: Alu Alloy/steel/Molded plastic

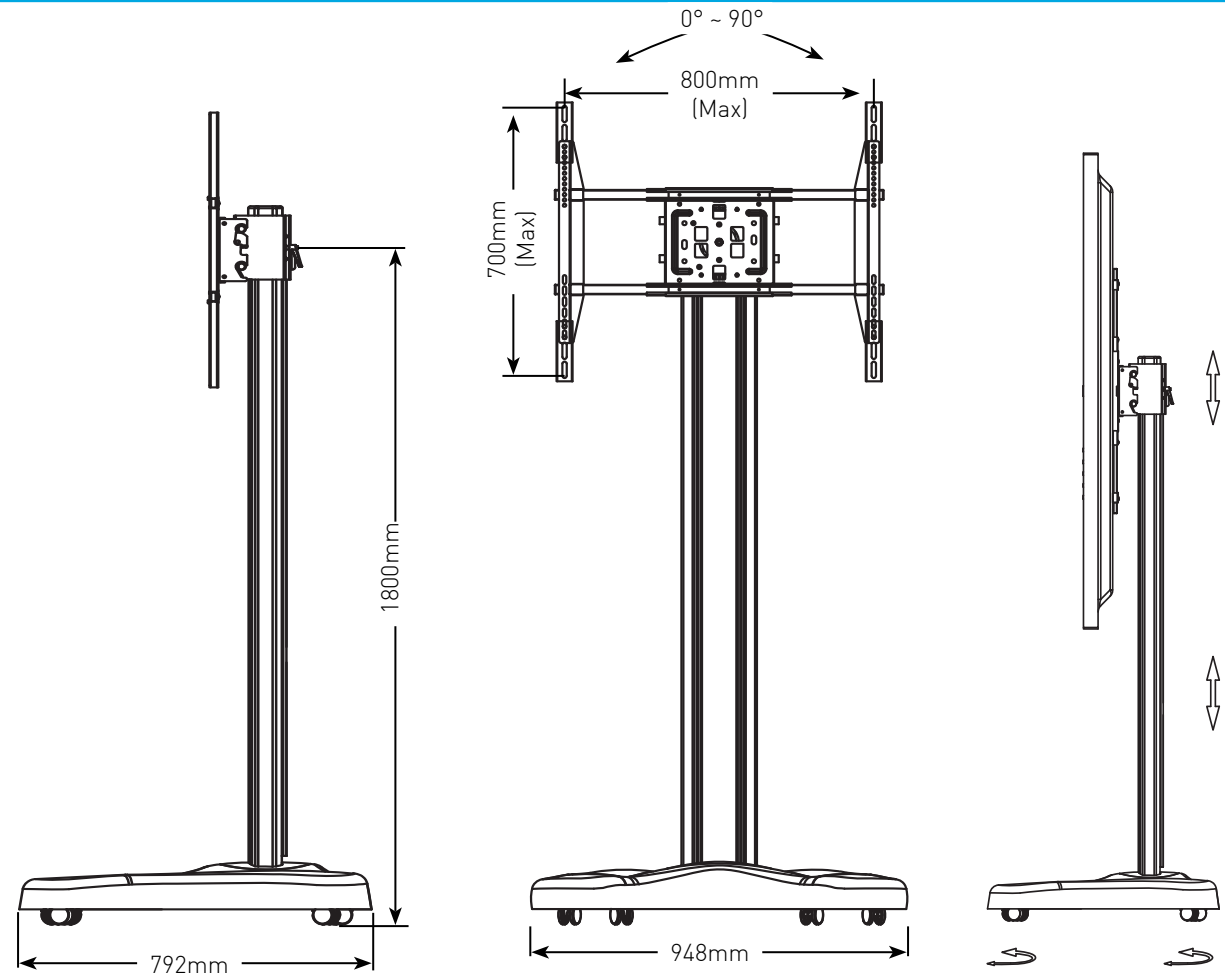

Product Code	Color	Max Weight Capacity (Kg)	Packaging dimensions W x D x H (mm)		Packaging Weight (Kg)
2C861	Silver anodized stand with Black base	90.5	Mobile Base Packaging	1015 x 880 x 200	20.0
			Mount and Post Packaging	1910 x 360 x 200	18.5